

Sliding Gate Opener

User Manual

DKC500DC/DKC800DC

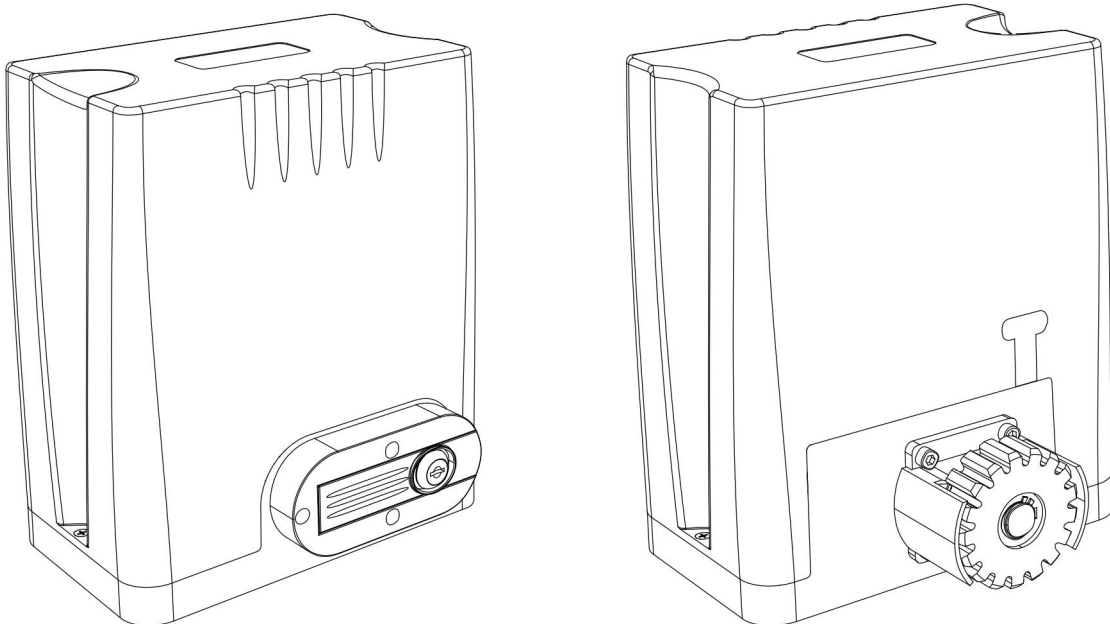

WARNING

Instructions must be read before installation. Please follow these instructions carefully, incorrect installation could affect gate operation.

When mounting and positioning this product please ensure the power cable is unplugged.

The motor cover will need to be removed to mount the motor to the mounting plate or directly to the concrete footing. Any changes to the settings on this product can only be made by a licensed electrician. This product can be powered by AC110V/220V power supply or backup battery power and solar power.

CONTENTS

Default Setting Instruction	1
Safety Instruction	2
Parts List	3
Technical Parameters	4
Installation	5
Before You Start.....	5
Tools Required / Example Sliding Gate.....	5
Step 1 - Gate Preparation.....	6
Step 2 - Checking Manual Release.....	6
Step 3 - Removing / Installing Motor Cover.....	6
Step 4 – Motor Pad Footing.....	7
Step 5 - Fitting Mounting Plate and Motor.....	8
Step 6 - Gear Rack & Motor Alignment.....	10
Step 7 - Limit Switch Stops.....	11
Step 8 - Powering on.....	13
Step 9 - Testing Travel and Limit Stops.....	13
Programming and Wiring	15
Terminal Instructions.....	16
Wiring to the Terminal.....	17
Input Status.....	18
Potentiometer Adjustment.....	18
Special Functions Setting.....	19
Remote Control Operation.....	19
Menu Setting.....	20
Connecting Infrared Photocells.....	22
Connecting Storage Battery(optional).....	23
Maintenance	23
Troubleshooting	24
Drawing and Measurements	25

Default Setting Instruction

The gate opener will open the gate to the right-hand side as its default setting. By default, the opener mounts on the right-hand side. (Figure 1)

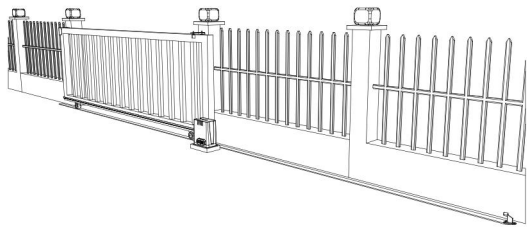

Gate in closed position

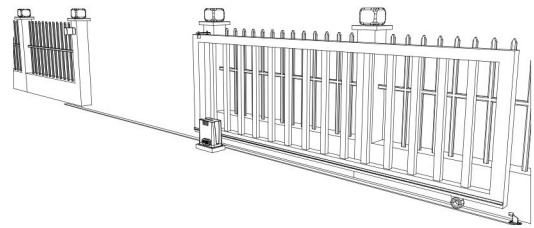

Gate in open position

Figure 1

Before installation: Test the gate opener by plugging it into a power source and pressing the remote. Press the opening button, the output gear rotates, then press the stop button, the output gear stops rotating. Finally, press the closing button, the output gear rotates to the opposite direction. This will give you an understanding of the way in which the opener will move the gate.

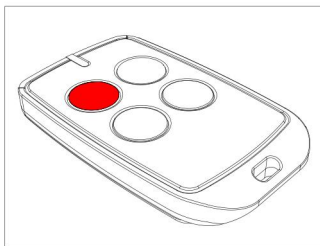

Press the first/top button on the remote.

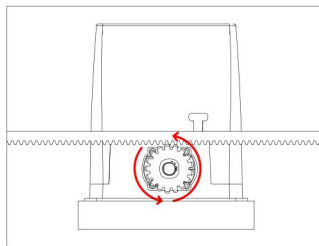

Rotating output gear will drive the gate frame.

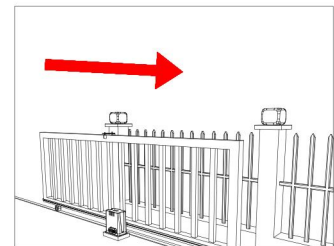

Then the gate will move in the set direction.

Figure 2

Note: Ensure that the gate opener is unplugged before proceeding with installation. Please keep fingers away from the motor output gear whilst it is turning.

If your gate needs to open from the other direction (to the left, refer to figure 3), your opener needs to be mounted on the left-hand side as shown, the relative wires need to be swapped over, please check under “Terminal Instructions” for swapping. (Factory default setting is for right-hand opening: opener mounted on the right-hand side).

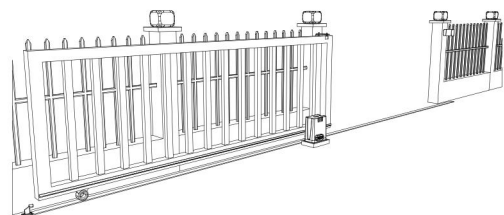
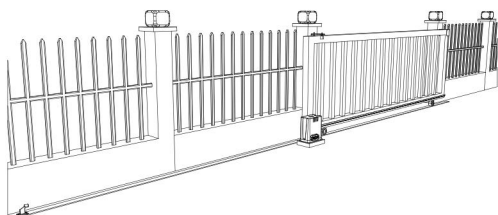

Figure 3

Any works done to the gate opener must be completed whilst the power is off, and the opener is unplugged.









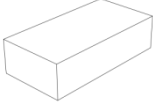
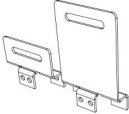

Safety Instruction

Warning: Incorrect or improper use of this product can cause damage to persons, animals or properties.

- Please ensure that the input voltage used matches with the supply voltage of gate opener.
- All modifications to wiring or electrics, and any adjustment or maintenance to input voltage must be done by a qualified electrician.
- All potential hazards and exposed pinch points of the gate must be eliminated or guarded prior to installation of this gate opener.
- Never mount any device that operates the gate opener where the user can reach over (under, around or through) the gate to operate the controls. These must be placed away from any moving range of the moving gate.
- Ensure power plug is disconnected from the power socket during installation or maintenance.
- Keep remote control and other control devices out of children's reach, in order to avoid unintentional activation.
- To ensure safety, before installing the motor, mount a Gate End Catch and a Gate Stop at each end of the rail to prevent the gate travelling off the track.
- If required, install infrared photocell to detect obstructions and prevent injury to person or damage to property.
- Instruct all users about the control systems provided and the manual opening operation in case of emergency.
- Ensure that the power cable is connected to a RCD protected weatherproof power outlet installed by a qualified electrician.
- Do not install this product in an explosive atmosphere or where there is any danger of flooding.
- This product was exclusively designed and manufactured for the use specified in the present documentation. Any other use not specified in this documentation could damage the product and be dangerous.
- Only use original parts for any maintenance or repair operation. Our company declines all responsibility with respect to the automation safety and correct operation when other supplier's components are used.
- Do not modify the automation components, unless explicitly authorized by our company.
- The user must avoid any attempt to carry out any works or repairs on this product, and should always request the assistance of qualified personnel.
- This product is suitable for use on one sliding gate only.
- Anything which is not expressly provided for in these instructions is not allowed and will void warranty.
- Dispose of all packing materials (plastic, cardboard, polystyrene etc.) according to current guidelines. Keep plastic bags and polystyrene out of children's reach.
- Save these instructions for future use.



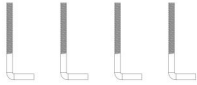
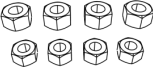



Parts List

Parts List (standard configuration)

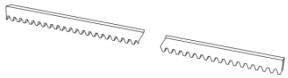
No.	Picture	Name	Quantity
1		Motor	1
2		Manual Release Keys	2
3		Remote Controls	2
4		Magnetic Limit Switch Accessories Box	1
4-1		Limit Switch Stop Bracket	1 set
		Magnet Limit Switch Stop	2
		Magnetic Limit Switch Stop Mounting Screws M6X18	4
		Nuts M8	4
		Flat Washers φ8	2
		Spring Washers φ8	2
5		Anchor Bolt M8	4
5-1		Nuts M8	8
5-2		Flat Washers φ8	8
5-3		Spring Washers φ8	8

Note: Extra flat washers and spring washers are spare parts.

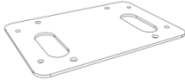
Parts List (optional)

No.	Picture	Name	Quantity
1		Galvanized Gear Rack	1m/pc
2		Nylon Gear Rack	1m/pc
3		Infrared Photocell	1
4		Wireless Keypad	1
5		Alarm Lamp	1
6		Mounting Plate	1
7		Hexagon Head Bolt M8X40	4

Additional remote controls: Spare/Additional remotes for the automatic gate kit, these will need to be paired to the motor.

Infrared photocell: Detects pedestrians, vehicles and objects that cross an infrared beam and prevents the gate from closing.

Wireless keypad: Allows secure access through the gate used with a user set code.

Wired control: Allow users to control the opening and closing of the door through an external push-button.

Alarm lamp: Alerts people near the gate and users that the gate is in operation.

Technical Parameters

Model	DKC500DC	DKC800DC
Power Supply	110VAC/60Hz; 220VAC/50Hz	
Motor Power	150W	170W
Gate Moving Speed	13m/min	18m/min
Maximum Loading Weight	500KG	800KG
Remote Control Distance	≥30m	
Remote Control Mode	Single button mode / Three button mode	
Limit Switch	Magnetic limit switch	
Working Noise	≤58dB	
Working Duty	S2, 20min	
Recording of up Remote Controls	25	
Remote Frequency	433.92 MHz	
Working Temperature	-20°C - +70°C	
Package Weight	10KG	11KG

Installation

Before You Start

- DKC500DC/DKC800DC Sliding Gate Automation Kit is suitable for powering the opening and closing motion of gates up to 500, 800kg in weight, up to a length of 8m.
- Gate motion is achieved by the rotating output gear of the gate opener driving the gear rack (sold separately) fitted to the moving gate.
- The gate opener requires you to press the remote control once to open, and once again to close. This is a safety feature to ensure safe operation.
- The opener must be fitted within private property, never externally to a property's boundary.

Any works done to the gate opener must be completed whilst the power is off and the opener is unplugged. Any modifications/alterations/works to AC power components must only be completed by a licensed electrician.

Tools Required

- Tape measure
- Level
- 12mm concrete drill and hammer (when uses expansion screws)
- Phillips head screwdriver
- Straight screwdriver

Example Sliding Gate

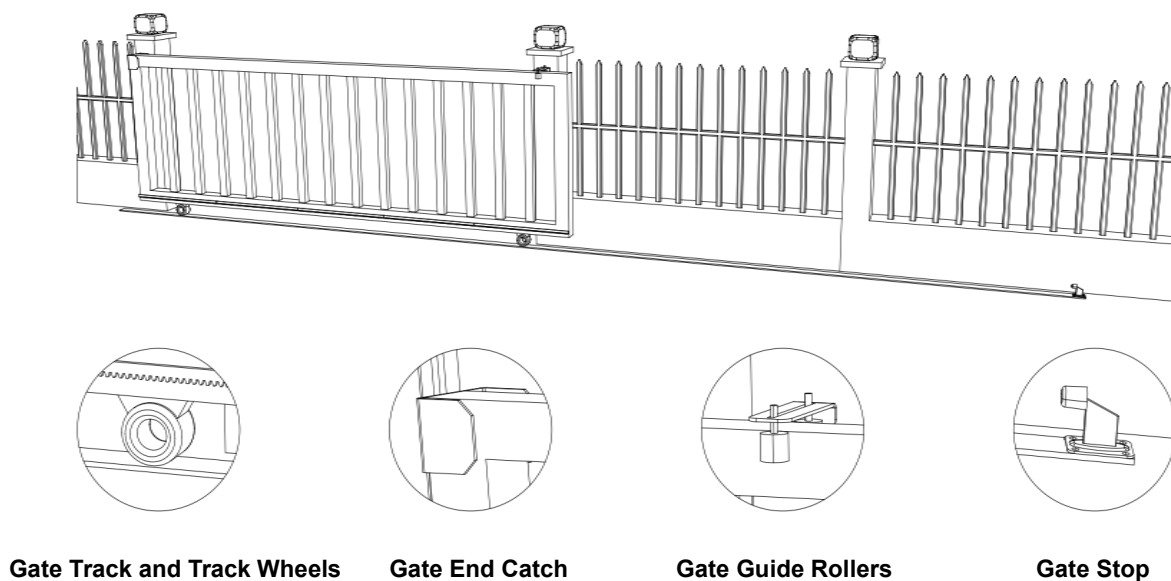
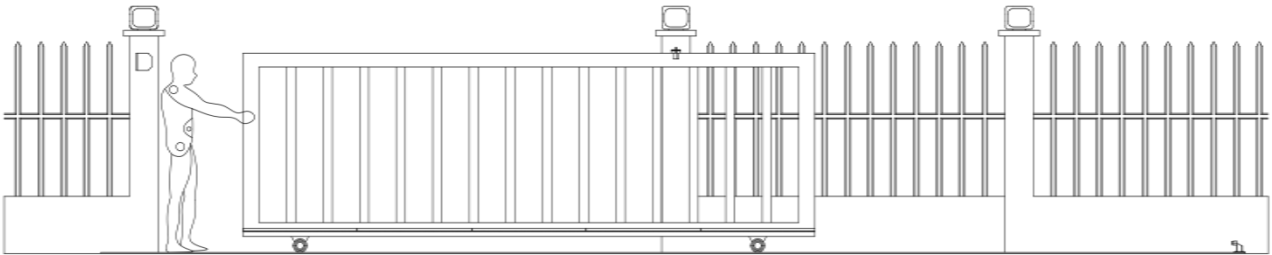

Figure 4

Please ensure that the gate opener power cable is not plugged in at any stage before Step 8.

Step 1 - Gate Preparation

- Ensure that the sliding gate is correctly installed.
- The gate is horizontal and level and the gate can glide back and forth smoothly when moved by hand before installing the gate opener.
- Wheels and guide rollers should rotate easily and be free from dirt or grime.
- Track should be flat, level and firmly affixed.
- Any misalignment in the gate will affect performance of the automatic gate opener.



The gate should slide smoothly by hand before attempting to install the gate opener.

Figure 5

Step 2 - Checking Manual Release

- Insert the key and open the manual release bar to enable the motor get into manual mode and check that the motor output gear rotates freely by hand (Figure 6).

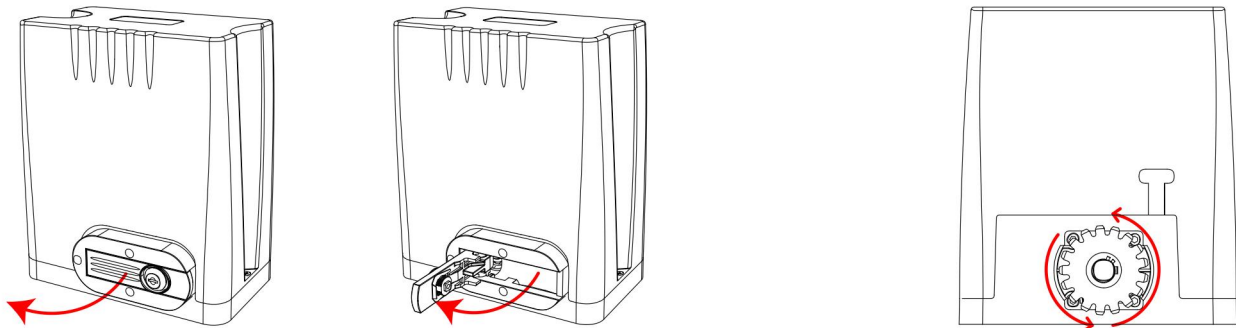

To make the motor into manual mode, insert the key and open the manual release bar as shown.

In manual mode, the gear can turn freely and the gate can be operated by hand.

Figure 6

Step 3 - Removing / Installing Motor Cover

- Unscrew the two cover screws located at each side of the motor cover.
- Remove the rubber grommet below the limit switch (Figure 7).

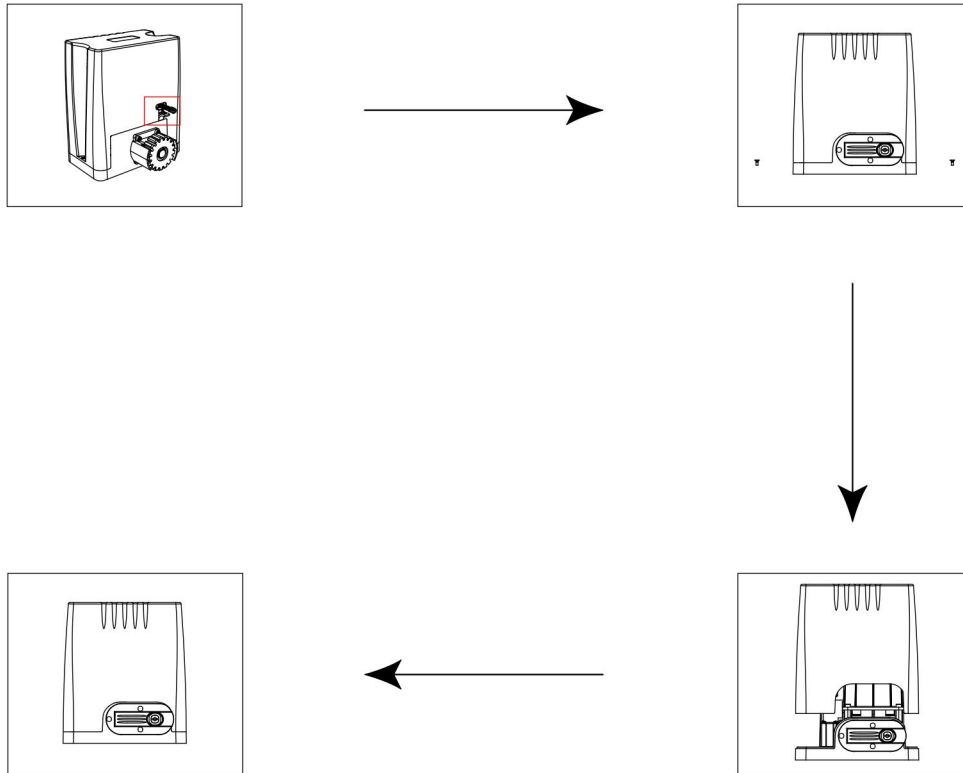
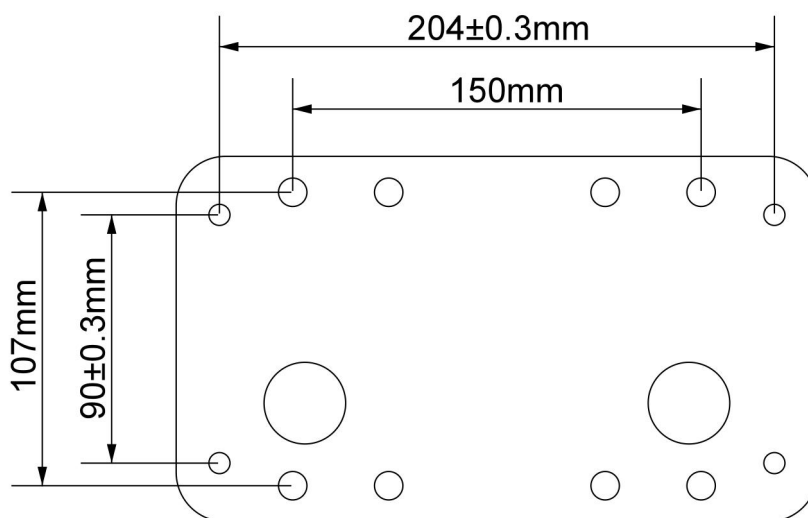

Figure 7

Please Note: the rubber grommet must be fitted back onto the motor cover once the cover has been re-fitted/replaced onto the base of the motor.

Step 4 - Motor Pad Footing

- The motor pad concrete footing requires an area of no less than 400mm long x 250mm wide and a minimum depth of 200mm (Standard requirement).
- Ensure surface is level and parallel to the driveway.



Mounting Plate Dimensions

Figure 8

Step 5 - Fitting Mounting Plate and Motor

Without Mounting Plate

- Pre embed the anchor bolts according to holes in motor base before concreting (as per Figure 9).
- After concrete hardening, bolt the motor with spring and flat washers provided and tighten as required. (The height can be slightly adjusted by bottom bolts as per Figure 10).

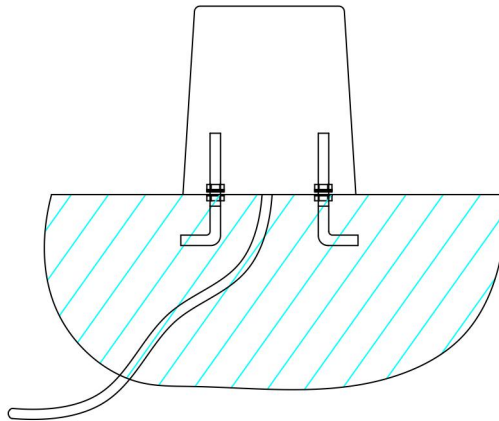
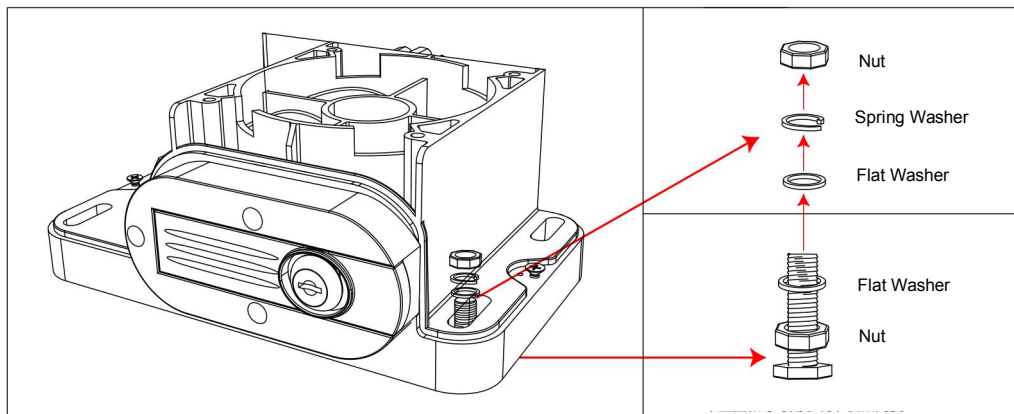

Figure 9



The bolts and flat washer between mounting plate and motor base are used for adjusting the height of the motor.

Figure 10

With Mounting Plate

- Pre embed the anchor bolts as per $\Phi 10$ holes in Figure 8 before concreting, after hardening, place the mounting plate, fit and tighten anchor bolts.(as per figure 11).
- Bolt motor to the mounting plate using the M8 x 40mm bolts with spring and flat washers provided and tighten as required (as per figure 12).

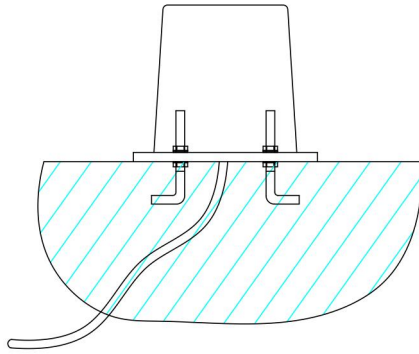
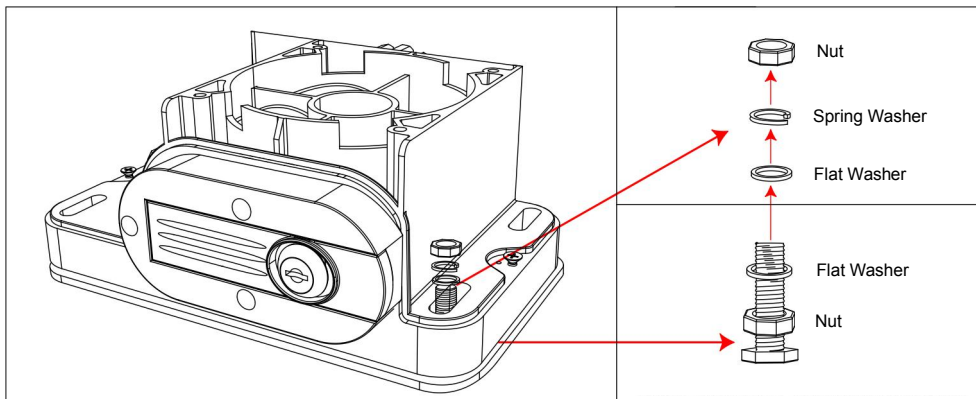

Figure 11



The bolts and flat washer between mounting plate and motor base are used for adjusting the height of the motor.

Figure 12

Fitting Motor

- Fit motor and mounting plate(if with) on the concrete footing.
- Ensure the motor output gear and gear rack are correctly aligned. Gear and gear rack should be centered as much as possible.
- Take the motor away from mounting plate.

Sliding Gate Frame (in open position)

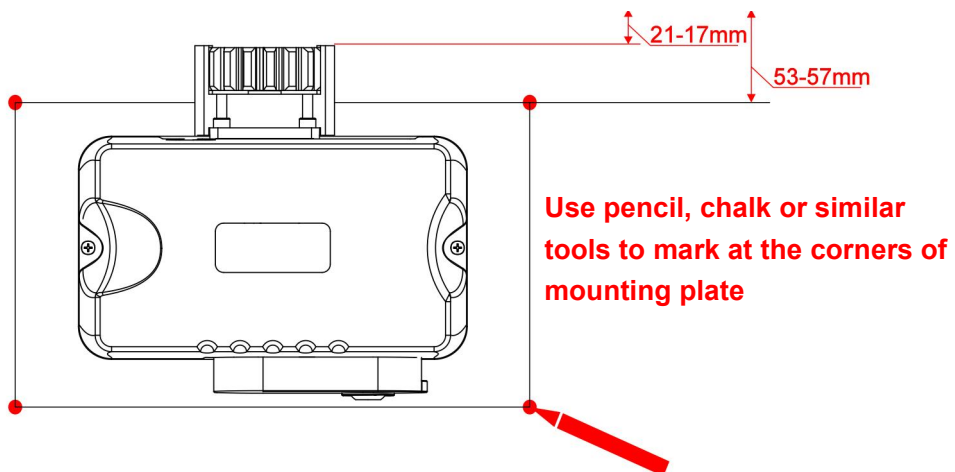

Figure 13

Step 6 - Gear Rack & Motor Alignment

- See Figure 15 for recommended gear rack mounting height.
- Ensure that the output gear has a minimum clearance of 1-2mm along the entire length of gear rack fitted to the gate (as per Figure 14)
- Ensure output gear and gear rack are correctly aligned. Under no circumstances should the gate opener output gear carry any weight of the gate. It is the task of the gate castors or wheels to carry the weight of the gate (as per Figure 14).
- If the gate doesn't slide freely by hand, adjust the height of the gear rack accordingly until the full length of gate slides freely by hand.

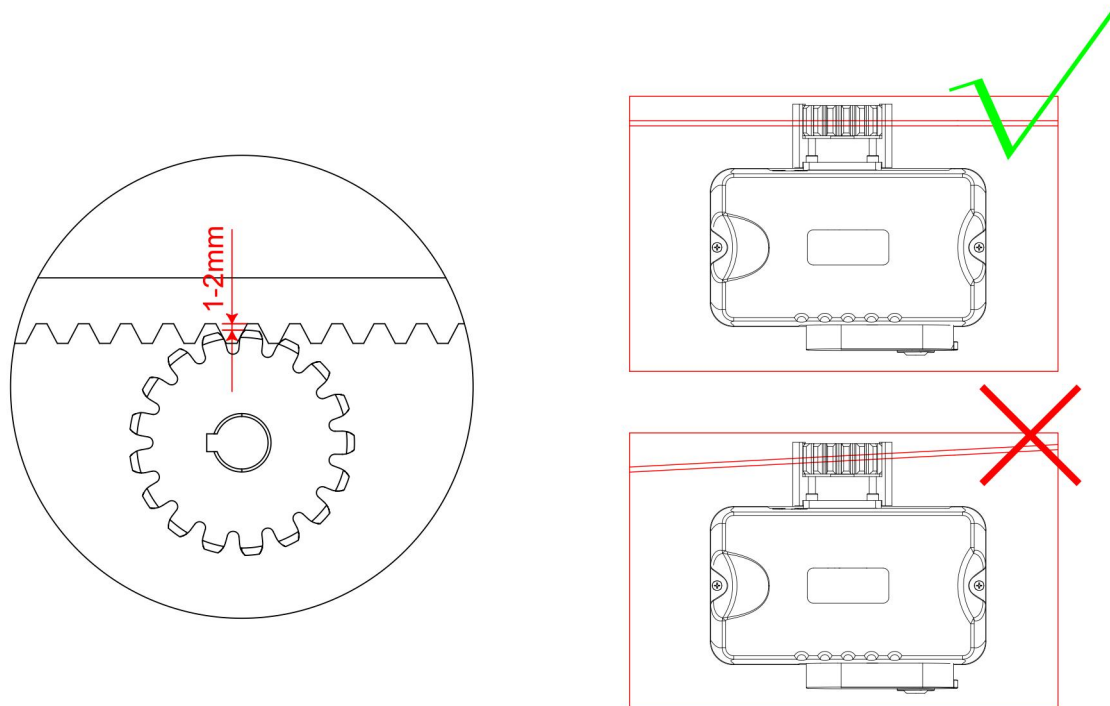

Figure 14

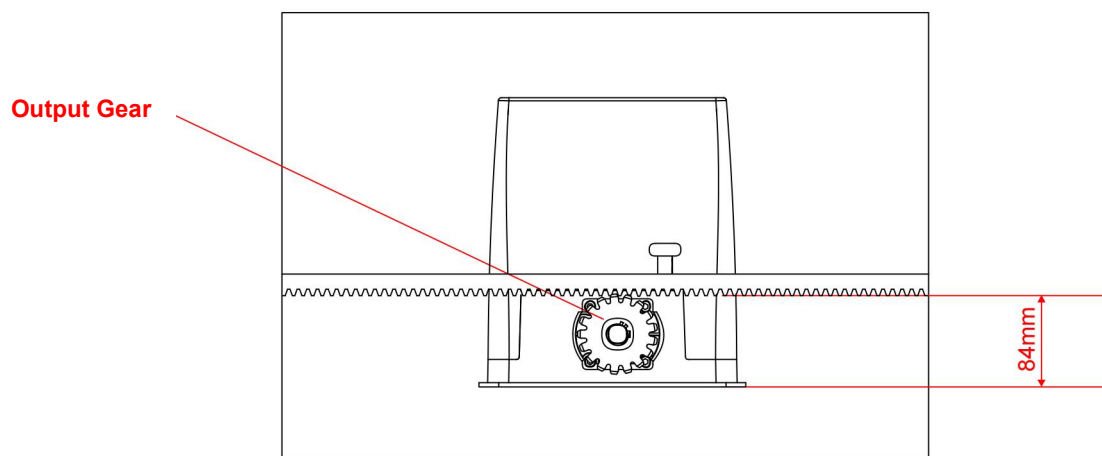
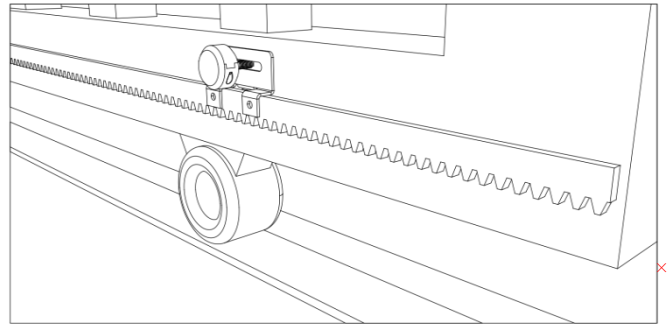

Figure 15

Step 7 - Limit Switch Stops

Included in your gate opener kit are two limit switch stops which must be fitted to the gear racks on your gate to ensure safe operation.

The limit switch stops are designed to set the desired opening and closing position of your gate. These limit switch stops are designed to come into contact with the magnetic limit switch.



It is extremely dangerous that without or incorrect installation of the limit switch stops can cause crash of gate, damage of internal structure of the motor, moreover, the gate may slide off the guide rail.

Setting the Limit Switch Stops

Closed Position

- Position gate 150-200mm back from the gate end catch closed position. This will help in making sure you do not slam the gate into the end stop/catch when setting the closed position under power.
- Fit limit switch stop onto the top of gear rack at the point where it meets the magnetic limit switch on the motor.
- Tighten locking screws of limit switch stop.

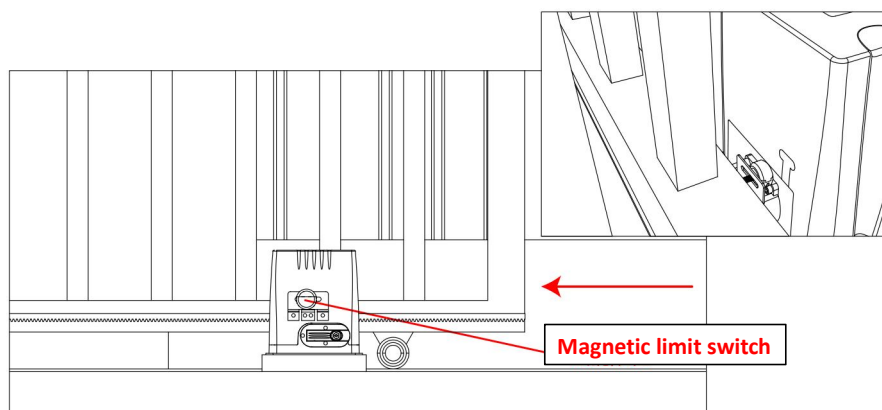

Open Position

- Position gate 150-200mm back from the gate stop open position. This will help in making sure you do not slam the gate into the end stop/catch when setting the open position under power.
- Fit limit switch stop onto the top of gear rack at the point where it meets the magnetic limit switch on the motor.

- Tighten locking screws of limit switch stop.

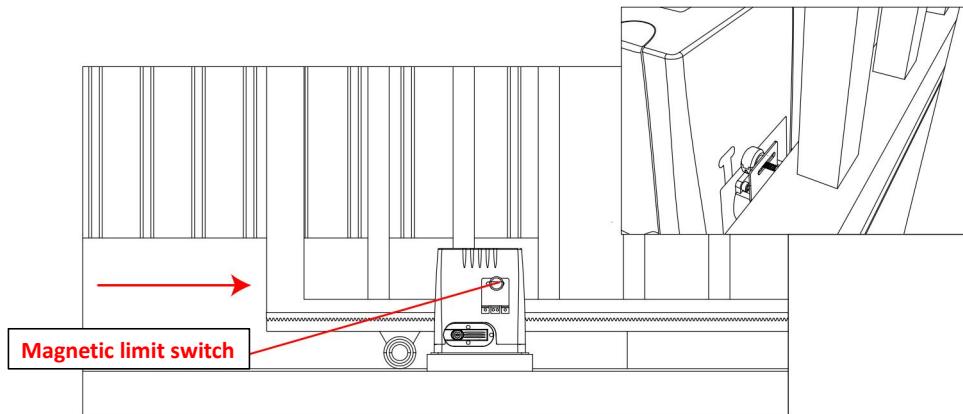

Test the spring/magnetic limit switch stops by moving the gate manually until you hear a click, making sure contact is made with the spring/magnetic limit switch on the motor.

To Reset: Turning the power off will reset the limit switch stop memory. Power on the gate opener again, pressing remote control or external push button switch to open and then close the gate once, then new limit switch stop setting is completed.

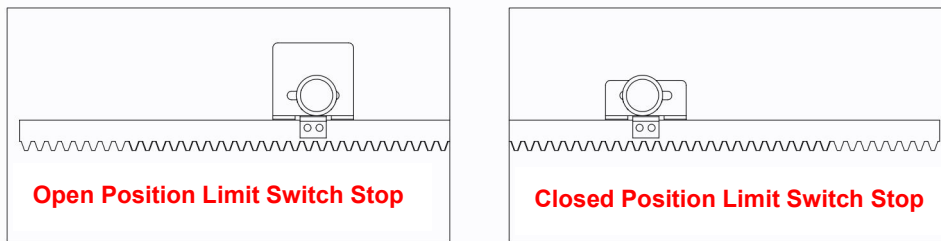

The installation of magnetic limit switch stops is shown in figure above.

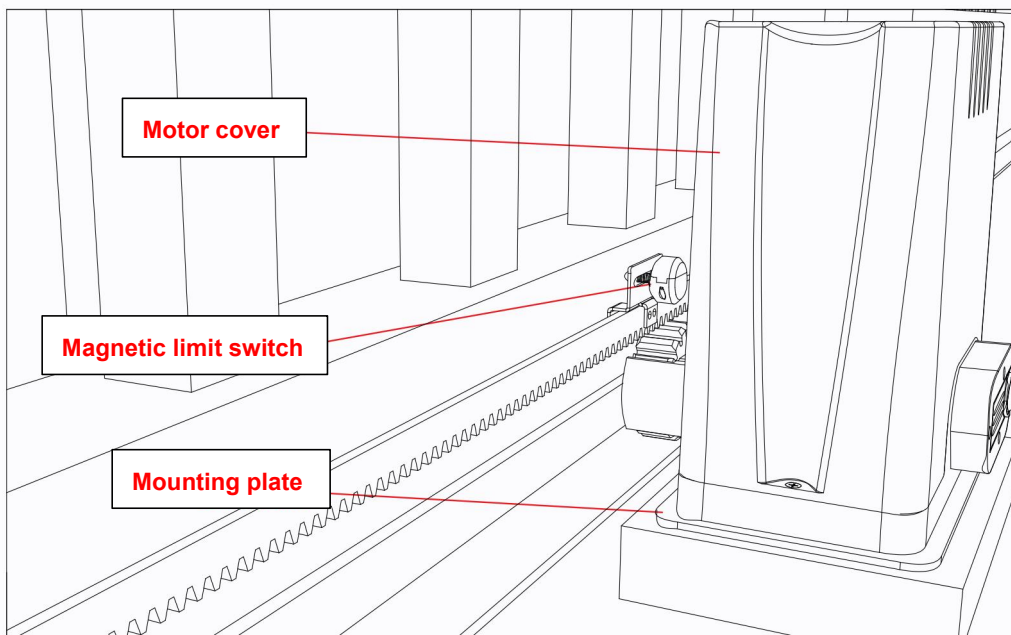

Open Position

Step 8 - Powering on

- Ensure that the outer cover has been fitted and fastened back onto the motor base.
- Before powering up the gate opener make sure the gate can travel by hand in manual mode (key unlocked).
- Slide the gate to between the middle of the posts, approximately (see below diagrams).
- Lock the manual release spanner (key locked) in readiness for automatic mode.
- Plug the power cord into an approved RCD protected weatherproof outlet.
- Remote controls included in this kit are factory paired ready for use.

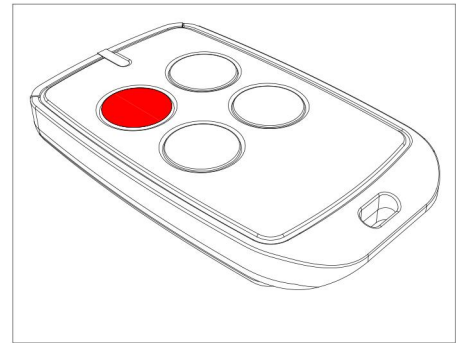
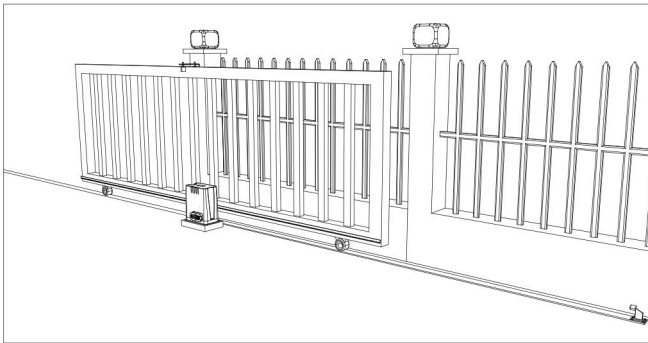

Figure 16

Step 9 - Testing Travel and Limit Stops

Testing the Closed Position

- Ensure gate opener is installed as per step 5, 6 and 7 and the sliding gate is in the middle position.
- Press remote (remotes included in kit are factory paired to the motor). The sliding gate will begin to close.
- The limit switch stop will hit the limit switch and the sliding gate will stop.
- When the gate stops, measure the distance remaining between the sliding gate and the desired closed position.
- You have now determined the closed position of the sliding gate when the limit switch stop hits the limit switch.
- Adjust the limit switch stop from the measurement you have taken to get your final gate closed position. The ideal closed final position for the gate frame is 10-15mm from closed gate end catch.

Testing the Open Position

- Press remote, the sliding gate will begin to open.
- The limit switch stop will hit the limit switch and the sliding gate will stop.
- When the gate stops, measure the distance remaining between the sliding gate and the desired open position.

- You have now determined the open position of the sliding gate when the limit switch stop hits the limit switch
- Adjust the limit switch stops from the measurement you have taken to get your final gate open position. The ideal open final position for the gate frame is 10-15mm from the gate stop.

To Reset:

- **When setting new limit stop positions please ensure that you turn the power off and then on again. Turning the power off will reset the limit stop memory, allowing for new limit switch stop positions to be recognized by the motor.**

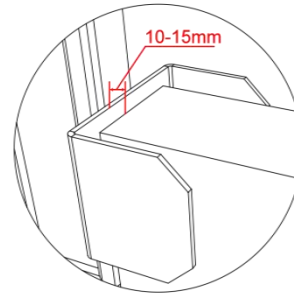
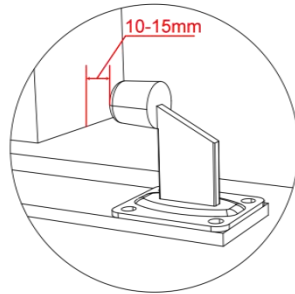

Now the basic open and closed positions are set, for further setting functions and adjusting parameters, please refer to pages 15-23 in this manual.

Programming and Wiring

Any works to the 110V/220V AC must only be performed by a licensed electrician.
Ensure power is off before any modifications are made.

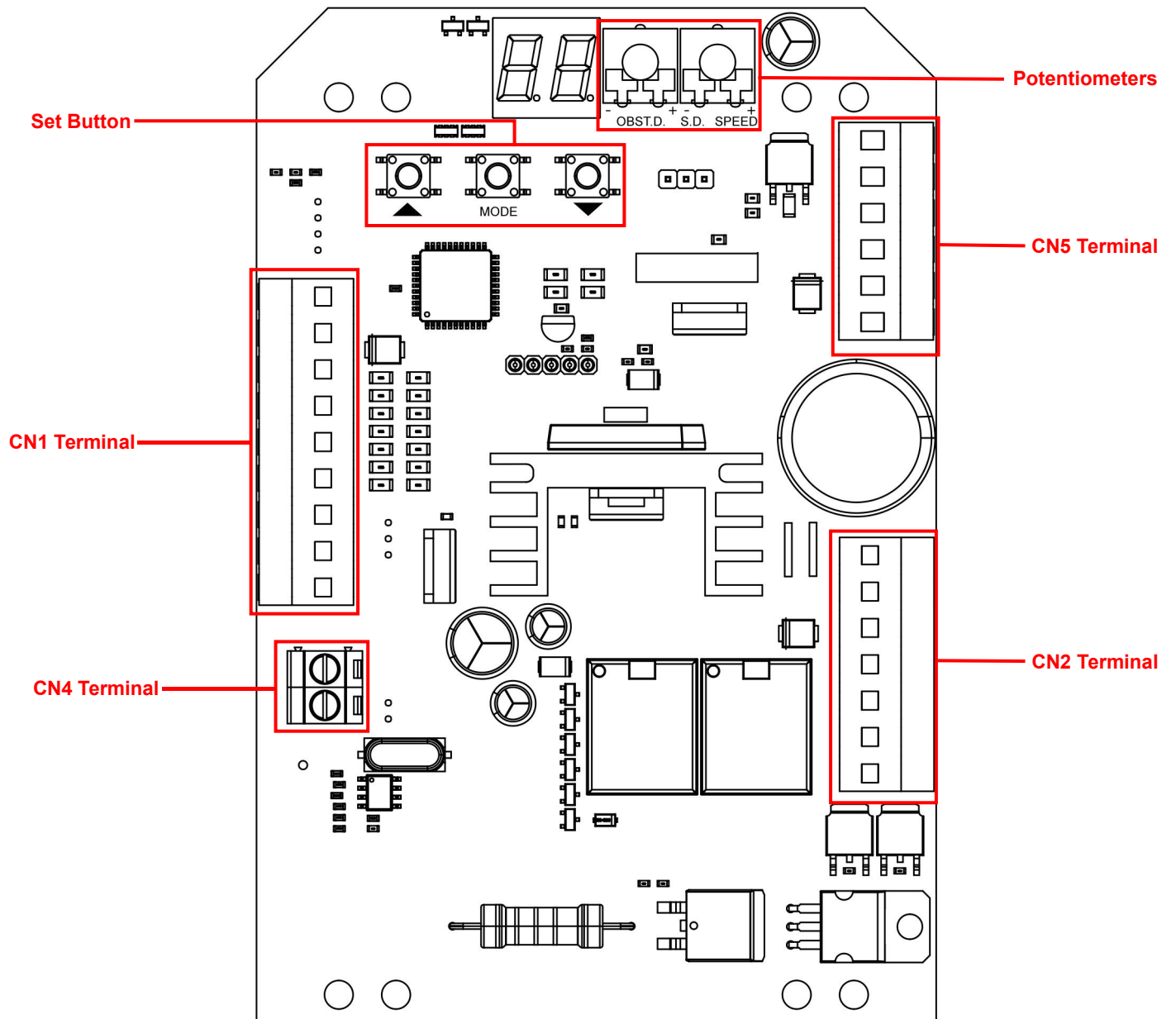
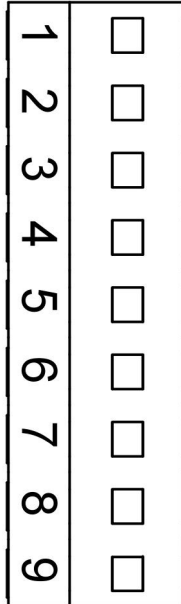

Figure 17

Terminal Instructions

All changes to these settings below must be completed by licensed electrician.



CN1 Terminal: External Push Button.

Terminal 1: External Open Push Button Switch.

Terminal 2: External Close Push Button Switch.

Terminal 3: External Stop Push Button Switch.

Terminal 4: Common Terminal for External Push Button.

Terminal 5: External Push Button Switch O/S/C Input.

Terminal 6: External Push Button Switch Pedestrian Mode Input
(Door opens for 1m)

Terminal 7: Close Limit Switch.

Terminal 8: Limit Switch Common Terminal.

Terminal 9: Open Limit Switch.

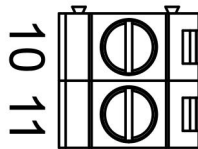

CN4 Terminal:

Terminal 10: Antenna

Terminal 11: Antenna Ground

Wiring to the Terminal

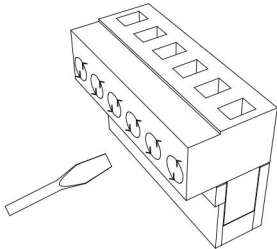

Using a screwdriver to loosen the screw on the side of the terminal.

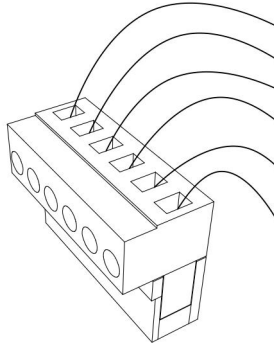

Insert the wire into the number on the terminal that you are looking to connect to. Refer to Page 15.

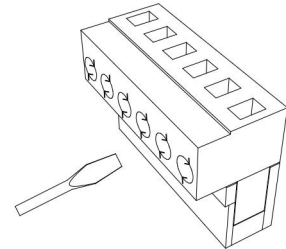

Tighten with a screwdriver to secure the wire in place.

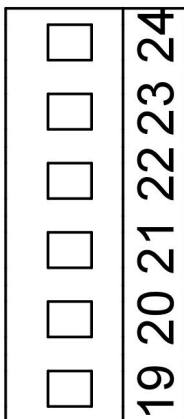

CN5 Terminal:

Terminal 24: Storage Battery +

Terminal 23: Storage Battery -

Terminal 22: Transformer Input 24VAC

Terminal 21: Transformer Input 24VAC

Terminal 20: Motor Wire

Terminal 19: Motor Wire

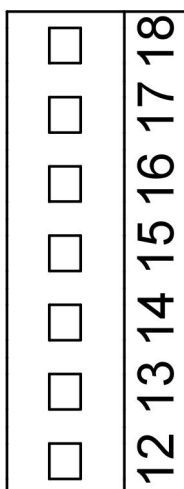

CN2 Terminal:

Terminal 18: Additional Accessories +24VDC

Terminal 17: Additional Accessories -24VDC

Terminal 16: Common Terminal for Photocell

Terminal 15: Photocell Input (N.C.). **If no photocell is fitted, use a jumper between terminals 15 & 16.**

Terminal 14: Photocell Emergency Stop Input (N.C.)

Terminal 13: Alarm Lamp +24VDC

Terminal 12: Alarm Lamp -24VDC









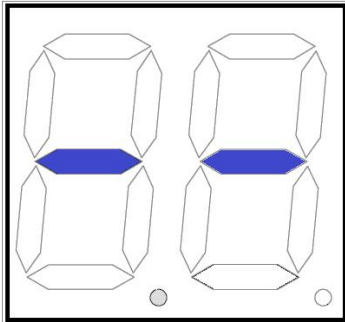

Additional accessories sold separately

Input Status

The digital display on the control board will indicate the current input status. If there is no

input, the screen will display 



	Stop Input
	Photocell Emergency Stop Input (N.O.)
	Photocell Input
	Photocell Emergency Stop Input (N.C.)
	Gate in Opening
	Gate in Closing
	Start
	Pedestrian Mode Activated
	Close Limit Activated
	Open Limit Activated

Potentiometer Adjustment

OBST.D. for Adjusting the Sensitivity of Meeting Obstacles

This potentiometer is for adjusting the sensitivity of meeting obstacles (clockwise to increase, anticlockwise to decrease). This adjustment will be made only after the travel learning is finished. Environmental change may influence the sensitivity (like strong wind), users can slightly adjust this potentiometer to ensure the best running of motor.

Note: The potentiometer is adjusted to its maximum, the obstacles detecting function will be disabled.

S.D.SPEED for Regulating the Slowdown Speed

This potentiometer is for regulating the slowdown speed. Do not set the speed too low (the minimum speed less than 6cm/sec.) to avoid that the gate opener can't operate normally after the gate condition been worse after years usage.

Lower Sensitivity

Higher Sensitivity

Lower Speed

Higher Speed

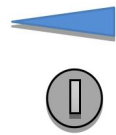

OBST.D.

Sensitivity of Meeting Obstacles

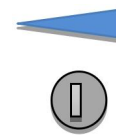

S.D.SPEED

Slow Down Speed

Special Functions Setting

Travel Record Setting

Generally, all settings on the control board was done before delivery(the pre-set is based on a 4m sliding gate), users can directly operate the motor after installation.

To record the travel, please cut off the power supply first, then completely open the gate by hand(from opened limit position to closed limit position), plug the power cord to get back the power supply, the control board will automatically record the gate current position and will set by itself the position for slow down speed of next closing cycle.

To clear the previous travel record, please re-set the control board or re-set travel.

Quick Travel Setting

Press and hold \triangle button until the digital displays  the gate opener will automatically run to it's closed limit position(for gate hasn't been completely closed), then will open to it's opened limit position, thereafter, it will close again to it's closed limit position, after which the travel learning is finished.

Note: If you are not sure about the running direction is to open or to close, before starting the travel setting, please close the gate by hand to it's closed limit position (completely close the gate) the control board will record the closed limit position and adjust by itself the

running direction. (refer to menu  for details)

Remote Control Operation

Pairing: Press ∇ button once, the digital will display , press the button on the

remote control, the digital will display corresponding number , remote control pairing is complete.

Deletion: Press and hold ∇ button until the digital displays , all paired remote controls are deleted.

Remote Control Intelligent Pairing

Remote control can be intelligently paired without opening the motor and programming on the control board. The precondition is there already has 1 paired remote control. The operation of intelligent pairing as follows:

Continually press the button on the unpaired remote control for 3 times, each time with interval of 2 seconds, then waiting for 2 seconds, press the button on the paired remote control for 3 times, each time with interval of 2 seconds, the pairing is finished after this step. If an alarm lamp is installed, it will flash once after successfully paired.

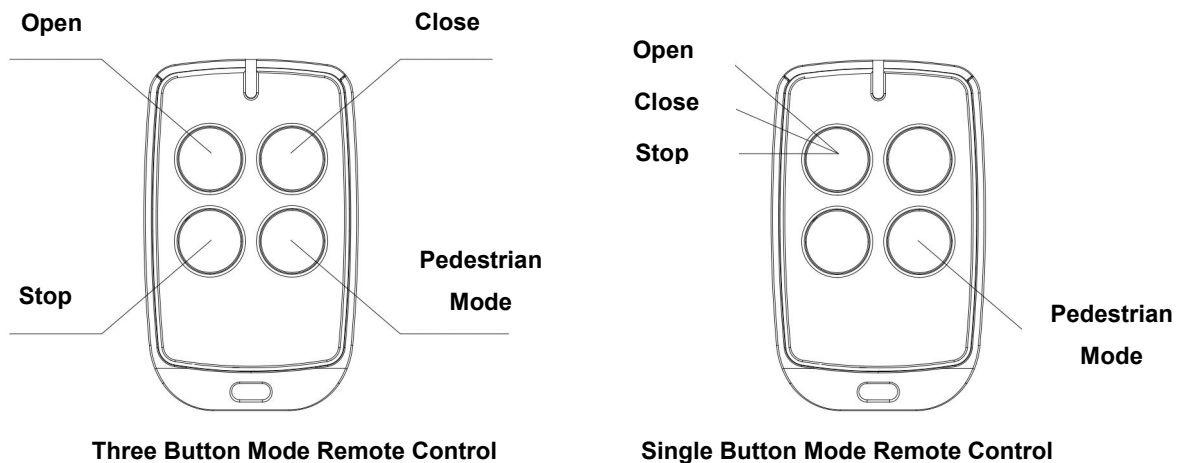



Figure 18











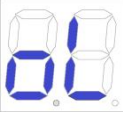



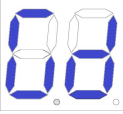



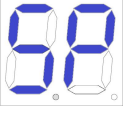

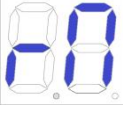

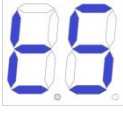

Menu Setting

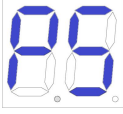
Press MODE to enter into menu, the digital will display the current selection , press

\triangle or ∇ to select other options. If need to exit the current menu, you can press 

button or press \triangle and ∇ buttons at the same time to exit.

If there is no action for 20 seconds, it will exit the current menu automatically.

Menu Press MODE to enter into menu	Selection Press Δ or ∇ to select, press MODE to confirm the selection	Default Status
 <p>Working Mode</p>	 Single cycle Mode  Single cycle mode with Auto-close function  Community mode	 Single cycle mode
 <p>Gate Opening Direction</p>	 Open to right  Open to left	 Open to right
 <p>Automatically Close Time</p>		 10 sec.
 <p>Remote Control Mode</p>	 Single channel  Four channels	 Single channel
 <p>Slowdown Speed Time</p>		 3 sec.
 <p>Photocell Emergency Stop Setting</p>	 N.C.  N.O.	 N.C.
 <p>Limit Switch Setting</p>	 N.C.  N.O.	 N.C.

Connecting Infrared Photocells

The below steps must be completed by licensed electrician.

Highly recommend the use of infrared photocells as an additional safety feature.

While closing, if the ray of the Infrared Photocell is blocked, the gate will stop and reverse immediately, to protect user and property security. To install photocells, connect wiring as per Figure 19. You must remove the wire jumper between terminal 15 and terminal 16 on CN2.

The distance between photocell receiver and photocell transmitter should not be less than 2 meters; otherwise, the induction effect of photocell may be affected.

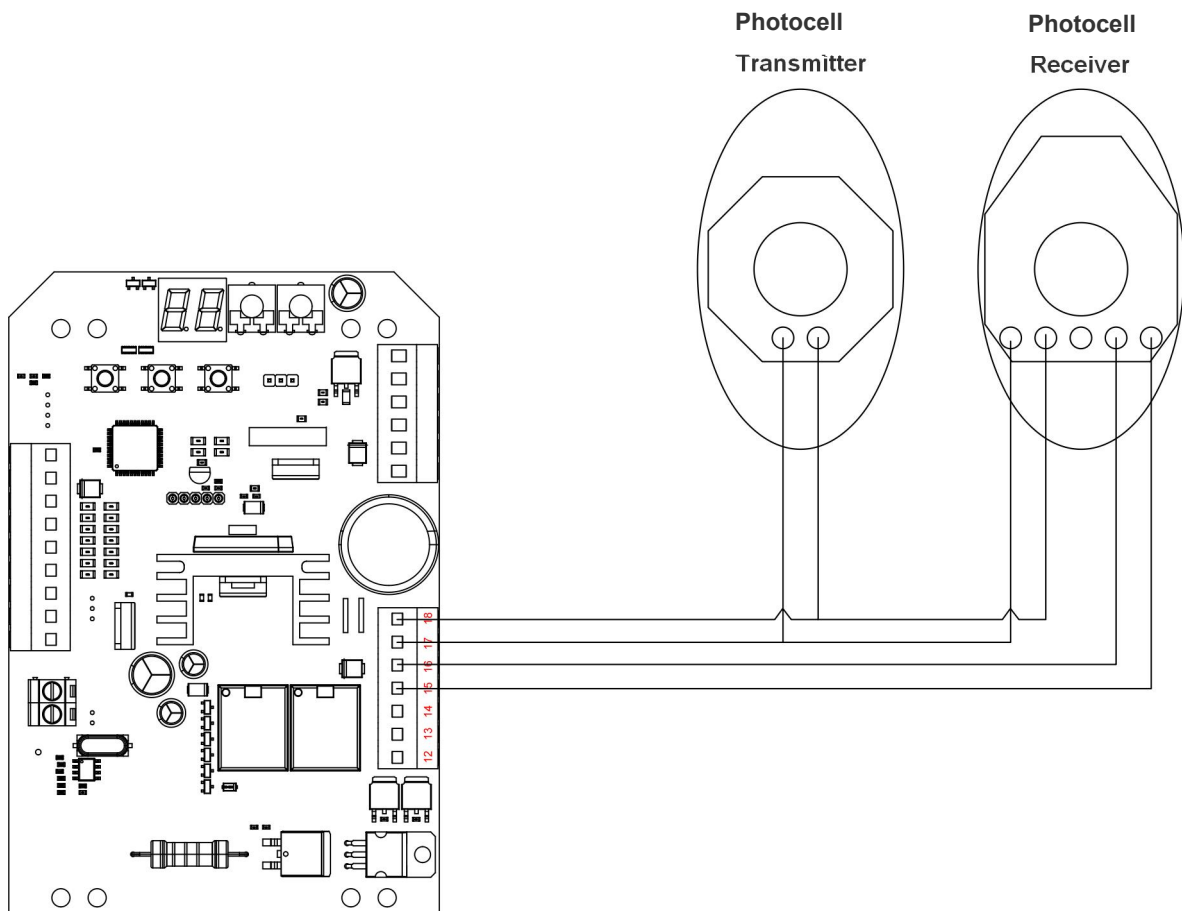

Figure 19

Connecting Storage Battery(optional)

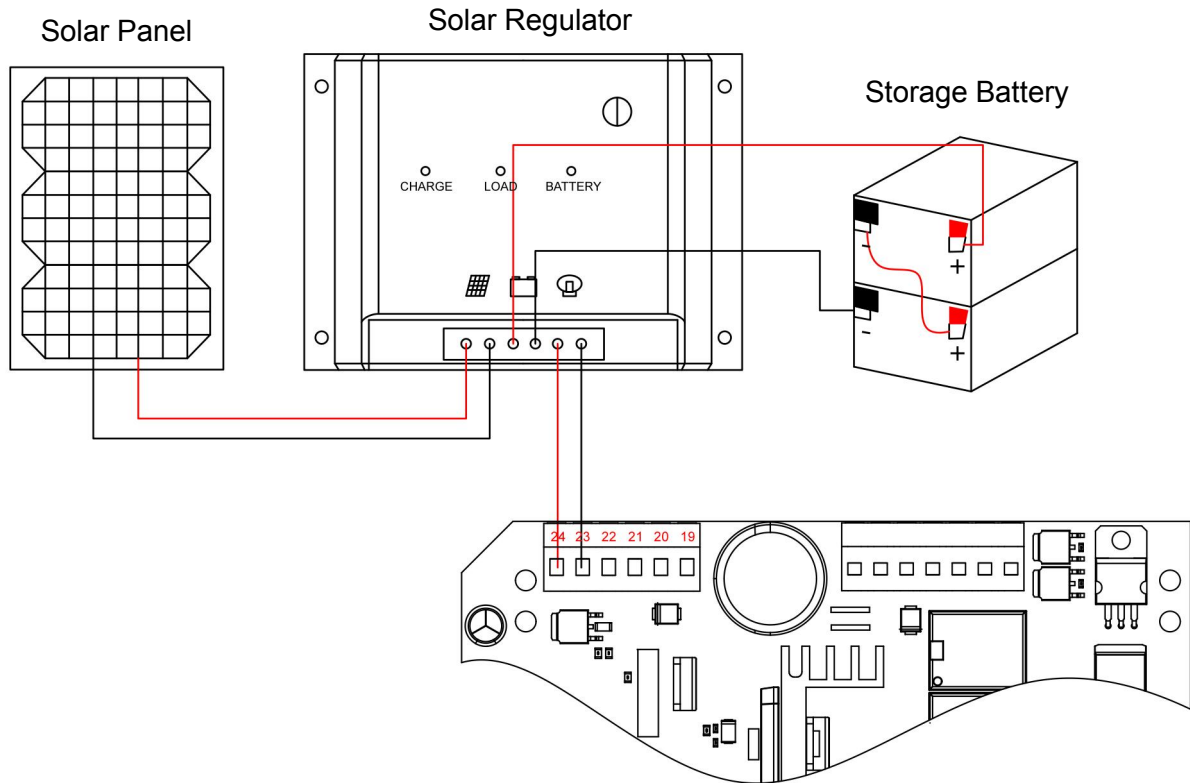

Figure 20

Maintenance

The gate should be checked every month to make sure it operates normally.

For the sake of safety, each gate is suggested to be equipped with infrared protector, and regular inspection is required.

Before installation and operation of the gate opener, please read all instructions carefully.

Our company keep the right to change the instruction without prior notice.

Troubleshooting

Any troubleshooting work below done to the motor must be completed by a licensed electrician and only whilst the power is off and the motor is unplugged!

Problem	Possible Reason	Solution
The gate cannot open or close normally, and LED does not light.	<ol style="list-style-type: none"> 1. The power supply is disconnected. 2. Fuse is blown. 3. Control board CN5 terminal wrongly wired. 	<ol style="list-style-type: none"> 1. Connect the power supply. 2. Check the fuse (FU) and replace if blown. 3. Re-wiring according to user manual.
The gate can only open, but cannot close.	<ol style="list-style-type: none"> 1. Photocell wrongly wired. 2. Photocell wrongly installed. 3. Photocell is blocked by obstacles. 4. Sensitivity of obstacle is too low. 	<ol style="list-style-type: none"> 1. If not connect photocell, please ensure terminal 15 and 16 has a jumper wire; if connect photocell, please ensure the wiring is correct and the photocell type is N.C. 2. Ensure that the photocell mounting position can be mutually aligned. 3. Remove the obstacle. 4. Increase the sensitivity of obstacle.
Remote control doesn't work.	<ol style="list-style-type: none"> 1. Battery level is too low. 2. Remote control not paired. 	<ol style="list-style-type: none"> 1. Change the battery. 2. Pair the remote control to the gate opener.
Press OPEN, CLOSE button, the gate is not moving, motor has noise.	<ol style="list-style-type: none"> 1. Capacitor damaged. 2. Capacitor is poor connected. 3. Gate moving is not smoothly 	<ol style="list-style-type: none"> 1. Change capacitor. 2. Check the capacitor wiring. 3. Adjust the motor or gate according to the actual situation.
Not stop when running to open or closed limit position.	<ol style="list-style-type: none"> 1. The open or closed limit switch is in opposite. 2. Magnetic limit switch badly installed. 	<ol style="list-style-type: none"> 1. Check whether the limit switch wiring is consistent with the motor running direction. 2. Check whether the distance and height between magnetic limit switch and motor reaches to standard requirement.
Leakage switch tripped.	Power supply cable short circuit or motor wire short circuit.	Check wiring.

Drawing and Measurements

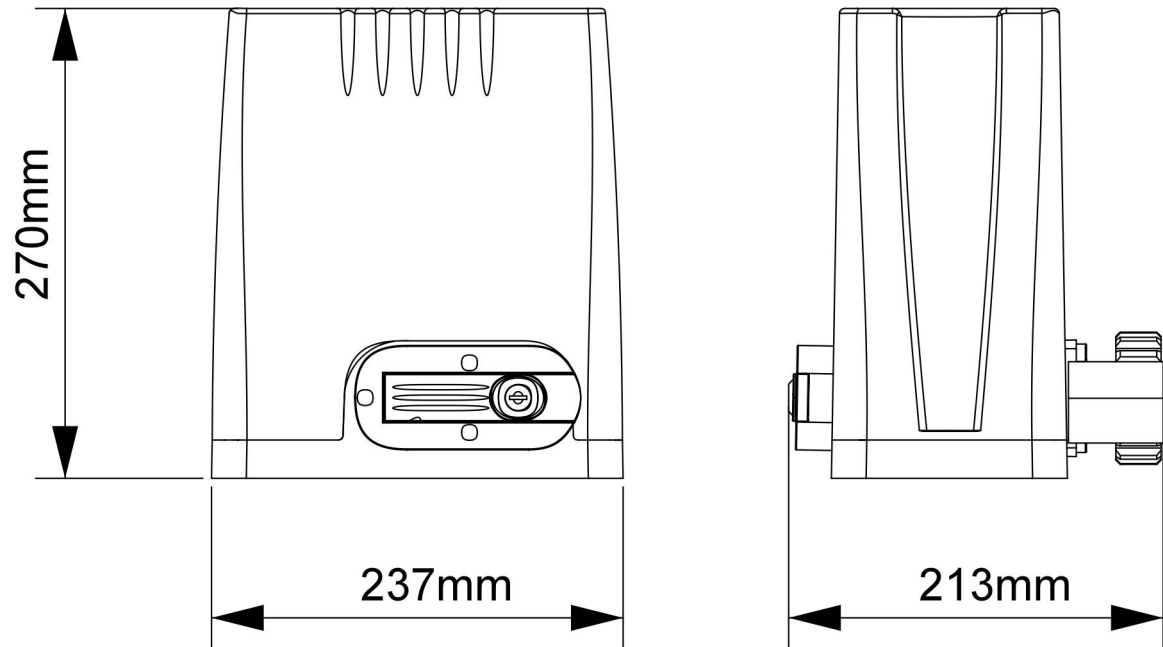

Figure 21